

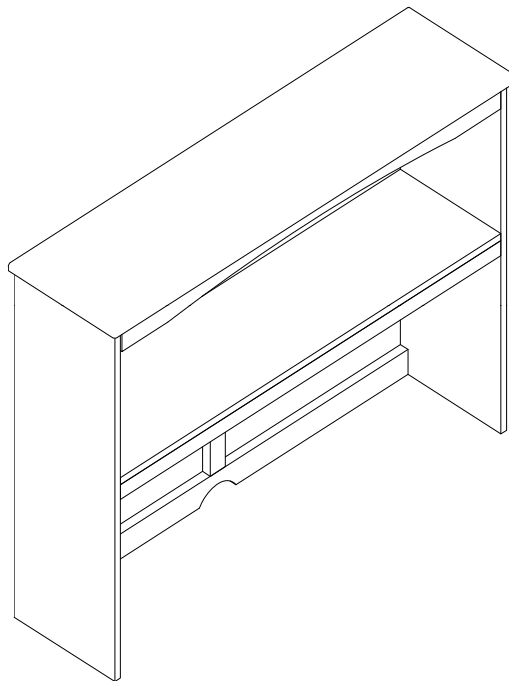

BOLTON
FURNITURE











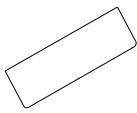



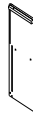

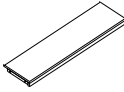
Assembly Sheet

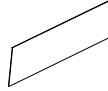
Wakefield Desk Hutch

133 Gallery Lane

Fax: 802-888-3668

NO.	DRAWING	DESCRIPTION	Q'TY	NO.	DRAWING	DESCRIPTION	Q'TY
A		TOP	1	I		HEX BOLT 35MM	12
B		LEFT SIDE PANEL	1	J		HEX BOLT 45MM	2
C		RIGHT SIDE PANEL	1	K		WOOD DOWEL	12
D		SHELF	1	L		WOOD SCREW	4
E		UPPER BACK PANEL	1	M		MENDING PLATE	2
F		BACK RAILS	2	N		HEX WRENCH	1
G		VERTICAL BACK RAILS	1	O		ANTI-TIP	1
H		CORKBOARD	2				

Step 1

Lay out and Identify all parts.

Step 2

Lay out all components for lower back assembly as shown on non-abrasive surface.

Insert 4 Wood Dowels (K) into Vertical Rail (G).

Attach Back Rails (F) to Vertical Rail (G) with 2 45mm Hex Bolt (J) using Hex Wrench (N).

Insert 8 Wood Dowels (K) into ends of Horizontal Rails (F).

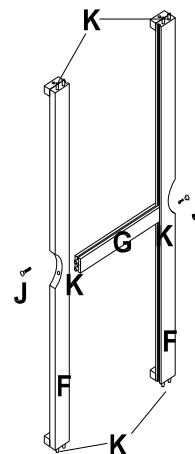

Step 3

Slide Corkboard (H) into upper and lower grooves of Horizontal Rails (F).

Position Right Side Panel (C) on a non-abrasive surface with threaded inserts and grooves facing up.

Place Wooden Dowels (K) into holes in Right Side Panel (C).

Make sure that Corkboard (H) is facing the inside of Right Side Panel (C).

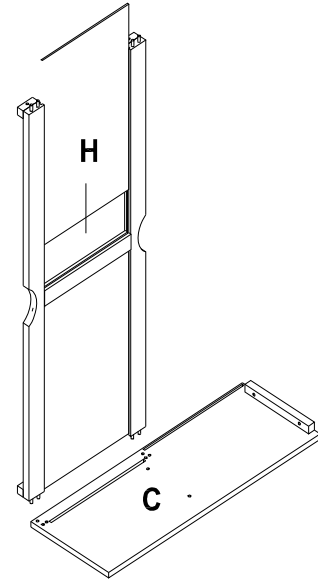

Step 4

Slide lower back assembly into place in groove in lower section of Right Side Panel (C). Attach Horizontal Rails (F) to Right Side Panel (C) with 2 35mm Hex Bolts (I) using Hex Wrench (N).

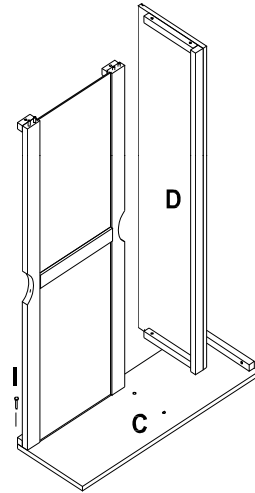

Step 5

Attach Shelf (D) to Right Side Panel (C) with 2 35mm Hex Bolts (I) using Hex Wrench (N).

Set Back (E) into groove in Right Side Panel (C) and Shelf (D).

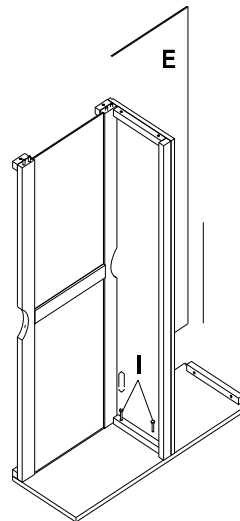

Step 6

Place Left Side Panel (B) on to hutch assembly lining up the Wooden Dowels (K) into correct holes.

Attach Left Side Panel (B) to Horizontal Rails (F) and Shelf with 4 35mm Hex Bolts (J) using Hex Wrench (N).

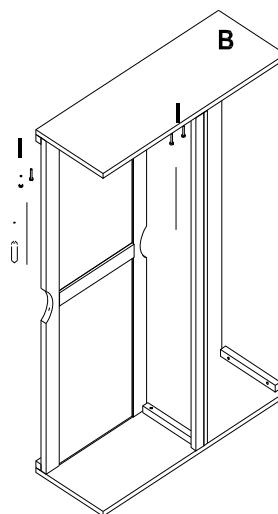

Step 7

Attach Top (A) to Left and Right Side Panels (B) + (C) with 4 35mm Hex Bolts (I) using Hex Wrench (N).

