

## **Assembly Sheet**

### **Emma - Twin - 4 Post Bed**

Replacement parts can be obtained from any Bolton Furniture authorized dealer.







249 Professional Drive, Morrisville, VT



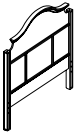

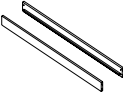
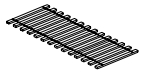

Phone: 802-888-7974

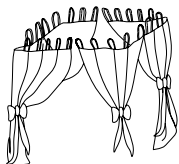
Fax: 802-888-3668

Web Site: [www.boltonfurniture.biz](http://www.boltonfurniture.biz)

## Parts List

NO.	Drawing	Description	Qty.
A		Twin Footboard	1
B		Twin Tall Headboard	1
C		Post-Long	2
D		Post-Short	2
E		Top Short Rails-2	2
F		Top Long Rails-2	2
G		Side Rails	2
H		Twin Bed Slats	1
I		Finials	4
J		Curtain	4

NO.	Drawing	Description	Qty.
K		100mm Hex Bolt	8
L		Cross Dowel	8
M		Allen Wrench	1
N		30mm wood screw	30
O		M8*70mm Headless Rods	4
P		M8*100mm Headless Rods	4
Q		Mushroom Plug	12

## Emma Twin 4 Post Assembly Instructions: Two people recommended for this assem

### Step 1

Verify that all parts are in box.

249 Professional Drive, Morrisville, VT

Phone: 802-888-7974

Fax: 802-888-3668

Web Site: [www.boltonfurniture.biz](http://www.boltonfurniture.biz)

## Step 2 - Attach Bed Ends to Side Rails

Position Bed Ends (A) & (B) and Side Rails (G) in approximate location where you want bed. Insert Cross Dowels (L) in holes on inside of side rails. Attach both side rails to bed ends by inserting 100mm Hex Bolt (K) through the upper holes on bed ends. Thread Hex Bolt into cross Dowels in side rails. Using Hex Wrench (M) tighten hex Bolts. SEE DIAGRAM

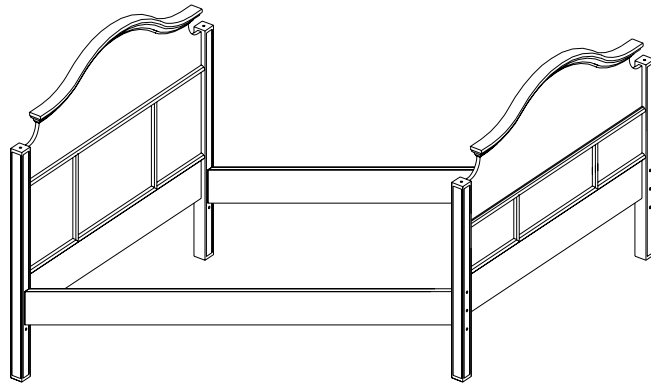
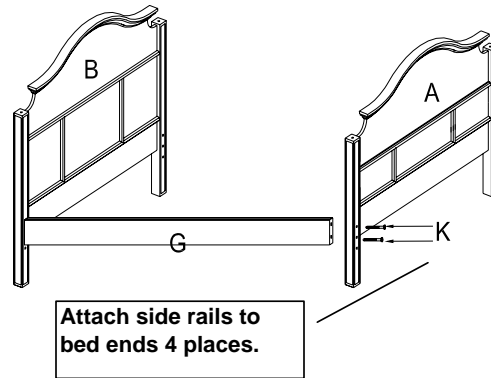

## Step 3 - Attach Slat Roll

Attach Slat roll (H) to cleats in side rails using 30MM Wood Screws (N). Every Slat must be securely attached to cleats on both ends of slat.

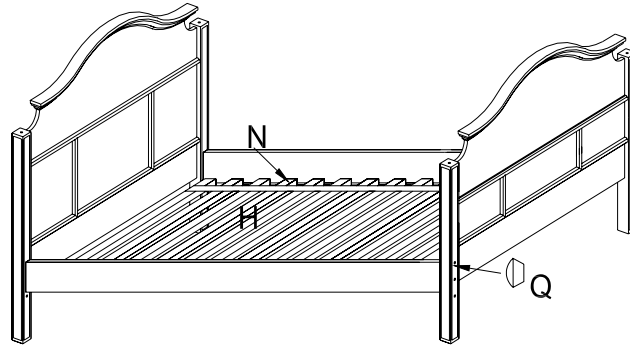

Insert Mushroom Plug (Q) into all counter sunk holes on Bed End post - 12 places.

## Step 4 - Attach 4 post

Thread Headless Rods (O) into Threaded Inserts in top of bed post - Do this on top of all 4 post. Thread Short Post (D) into Headless rods on Headboard bed post and Tall Post (C) into Headless rods on Footboard post.

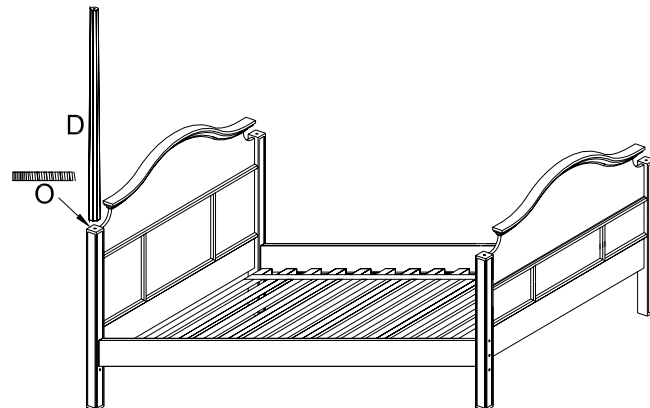

### Step 5 - Attach Top Rails and Curtains

Thread Headless Rods (P) into Threaded Inserts in top of Short Post (D) and Tall Post (C). Loop two long Curtains over each Long Top Rail (F) and two short Curtains over each Short Top Rail (E).

Align predrilled holes in Long Top Rails and Short Top Rails to the Threaded Inserts in top of post. Thread Finials (I) to the Threaded inserts in top of post - 4 places.

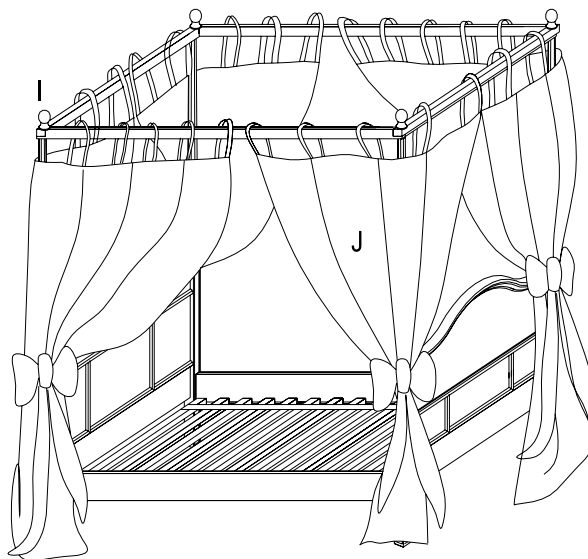
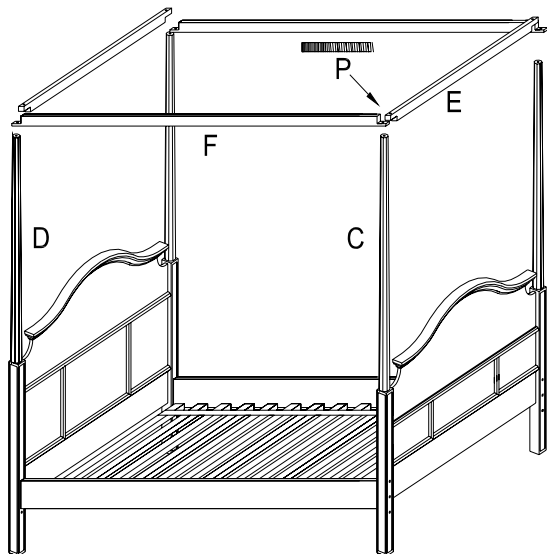

---

This Completes the Assembly of the Emma Twin Bed w/ Low Headboard