

# BOLTON FURNITURE

## ASSEMBLY INSTRUCTIONS

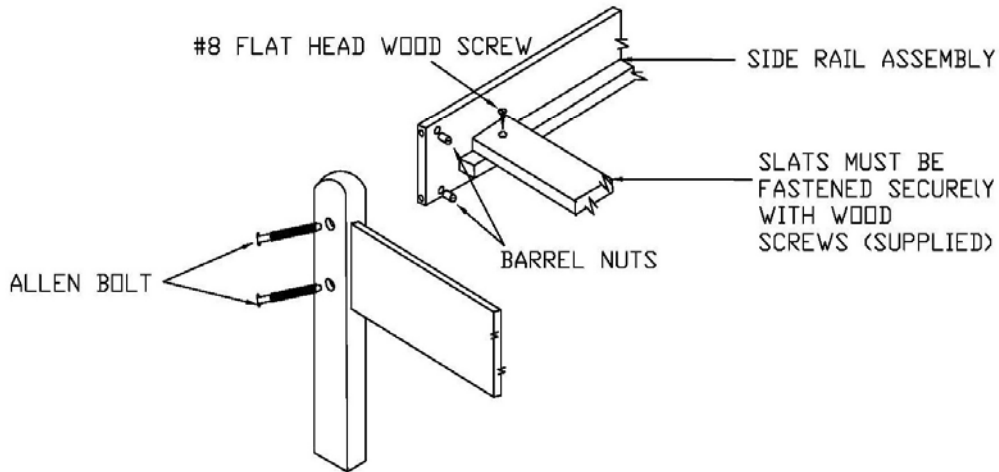

### **Bed Assembly**

Tools Necessary for Assembly:

Allen wrench (included), a phillips screwdriver and a Flat tip screwdriver.

### **Parts List**

#### **Twin Bed:**

Main components in boxes:

- (2) bed ends, (2) side rails,
- (1) slat roll which include (14) slats each (do not remove the webbing strips from the slat roll).
- (2) Twin Bed hardware package includes: (8) 3 1/4" Allen head bolts, (1) Allen wrench, (8) barrel nuts, (8) Wooden Plugs and (28) #8 wood screws for the bed slats.

#### **Twin Bed Assembly:**

- 1) Insert the barrel nuts into the holes in the inside of the side rails with the slot for the screwdriver facing out, as shown in the diagram.
- 2) Attach the side rails to the bedends. Insert the Allen head bolts through the two holes in a leg of the bed end and into the barrel nuts in the end of the side rails (see diagram). Tighten the bolts with the enclosed Allen wrench. Attach side rail to one end and then repeat for the other side. Do not tighten the joint connector bolts completely until all hardware is in place.
- 3) Once the bed is completely assembled, tighten the Allen head bolts completely.
- 4) Place the slat roll on top of the wooden cleat and secure by using #8 wood screws. Make sure that the spacing between each bed end and first slat is no more than 3 1/2 inches. Note: The webbing should be on the top.

Replacement parts may be obtained from any of our Bolton Furniture or Vermont Precision Woodworks dealers.



**249 Professional Drive  
Morrisville, VT 05661**

**Tel: 802-888-7974**

**Fax: 802-888-3668**

**Website: [www.vtprecision.com](http://www.vtprecision.com)**

## **Assembly Sheet for B-3 Twin Bed**